

---

# Introduction to Control and Instrumentation

Course No: E04-037

Credit: 4 PDH

---

Manuel Gooding, P.E.

---



Continuing Education and Development, Inc.  
22 Stonewall Court  
Woodcliff Lake, NJ 07677

P: (877) 322-5800  
[info@cedengineering.com](mailto:info@cedengineering.com)

---

**INTRODUCTION TO CONTROL AND  
INSTRUMENTATION**

# INTRODUCTION OF CONTROL AND INSTRUMENTATION

TABLE OF CONTENTS	<b>Error! Bookmark not defined.</b>
INTRODUCTION	3
Definitions	4
Instrumentation	4
Control System	4
Process Control	4
Variables	4
Control Loop	4
CONTROL LOOP DESCRIPTION, ELEMENTS, AND TYPES	5
Open Loop	5
Closed Loop	5
Comparison between Closed and Open Loops	6
Elements of a Control Loop	7
PRIMARY SENSORS	9
Instrument Characteristics	9
PRESSURE	10
Definition	10
Atmospheric Pressure	12
Gauge, Absolute and Differential Pressure	12
Other pressure units	12
Pressure Sensors	13
Pressure Instrument Calibration	14
Pressure Instruments Figures	15
Definitions	18
Temperature Sensors	19
Temperature Sensors – Length Based	19
Electrical Based Temperature Sensors	21
LEVEL	23
Level Sensors	23
Level Sensor and Transducers Figures	26
FLOW	28
Flow instruments	28
Figure 19 – Pressure tube location for DP measurements	
Other Methods for Measuring Flow Rate	30
MOTOR CONTROLS	33
Introduction	33
Motor Controllers	33
Motor Control Elements	35
Starters	36
Modern Automatic Motor Controls	39

# INTRODUCTION OF CONTROL AND INSTRUMENTATION

## INTRODUCTION

This course will present the following areas of control and instrumentation:

- 1) Control Loop definition, elements, and types
- 2) Study of elements of the control Loop:
  - a) Set point, controllers, and amplifiers
  - b) Sensors and transducers
  - c) Instrument and measurements
  - d) Motors, valves, and actuators
  - e) Final Control Elements
    - i) Electrical such as heaters, generators, etc.
    - ii) Mechanical such as valves, levers, etc
- 3) Basic of motor controls
- 4) Control circuit diagrams

Instrumentation and control is the nervous system of industrial complexes, power generation, and basically all the processes that require some intelligence to accomplish the task of producing a product or process.

When a process is modified to improve its function, the best and most economic change of the system is to improve the control and occasionally the instrumentation areas.

Quality, quantity, and efficiency are directly related to the control and instrumentation systems. The efficiency of the controls reflects directly in the profitability and quality of the product or service obtained from a process or system.

Examples of other benefits obtained by applying control systems are evident in environmental controls, which help to manage the waste and regulate the interface between the system and the environment. One application in this area is seen in control of emissions which use specialized instruments and controls to decrease the impact of pollutants in the atmosphere.

The growth of the computer industry and its techniques has provided expanding technology in the controls area, consequently producing more efficient and sophisticated systems. These systems now control more precisely the production of goods and information given to operators to refine the quality of products and services.

This course will walk you through the elements that make a control system and present to you the most common instrumentation used in industry.

# INTRODUCTION OF CONTROL AND INSTRUMENTATION

## ***Definitions***

### **Instrumentation:**

Use of technology and devices to detect and control physical and chemical characteristics of materials; this includes motion, light, color, acidity, etc.

### **Control System**

A system that takes the information from instruments of a process manipulating it using logic (algorithms) then applying the results to a process or system to change its characteristics.

### **Process Control**

A control system that is used in the process and chemical industries. A process control has the characteristic of automatically regulating a process. Automatic in this context means that the process is controlled without the need of human intervention.

### **Variables**

Are defined as the characteristic of the process. Some variables are temperature, speed, humidity, viscosity, density, etc. There are two basic types of variables: measured or controlled, and manipulated.

### **Control Loop**

Control loop is a control system architecture that will manage a process using elements that sense, adjust, and act upon the process. We can define it as the configuration by which the control system manipulates the control parameters.

## INTRODUCTION OF CONTROL AND INSTRUMENTATION

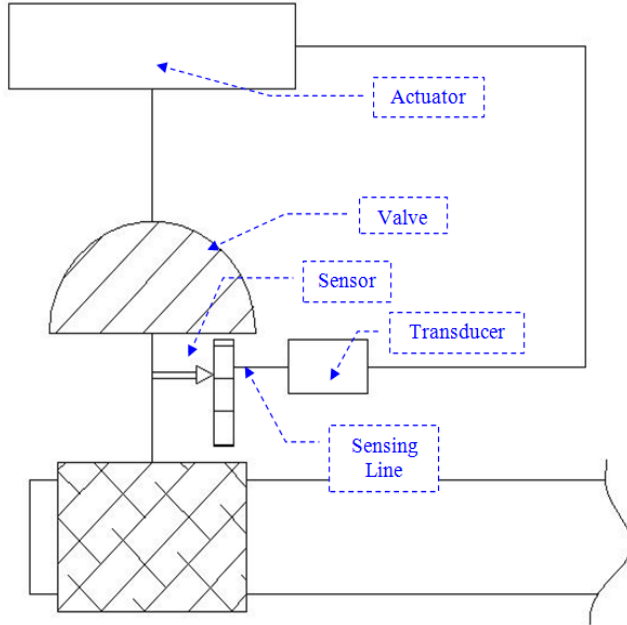

Figure 1

## CONTROL LOOP DESCRIPTION, ELEMENTS, AND TYPES

### Open Loop

The control loop configuration should be **open**, as in the control of a valve to open. The controller receives the signal to open the valve. That operation is completed without additional action. The loop is open because it starts at the open command and ends at the valve opening. This is known as an open-ended control.

### Closed Loop

A **closed loop** defines the action of sending a signal to a modulating valve to open it half way; the controller applies the open signal until the valve reaches the half way point. The position of the valve is determined by an instrument that detects the position and sends the signal back to the controller to close the loop. The loop is made from the controller to the valve actuator to the position device to the controller. See Figure 1 for a closed loop control.

# INTRODUCTION OF CONTROL AND INSTRUMENTATION

## Comparison between Closed and Open Loops

Open Loop	Closed Loop
A measurement is detected	A measurement is detected
Monitoring is performed (usually manually)	Measurement is compared to a set value
No adjustment is made	Adjustment is made to the process
Return to measurement	Return to measurement, repeating the adjustment until the set value and measurement are equal.
<b>EXAMPLES</b>	
<i>A conveyor belt carrying material</i>	<i>Tank level control</i>
A measurement is made (scale)	A level sensor feeds measurement to a transducer
An alarm bell performs monitoring	A comparison is made to set point at the controller
Reporting: Activation of alarm is made if weight is exceeded	Action: If level is low a signal is sent to an inlet valve to open. If level is high or equal to the set point a signal is set to inlet valve to close

**Table 1 – Open and Close Loop Examples**

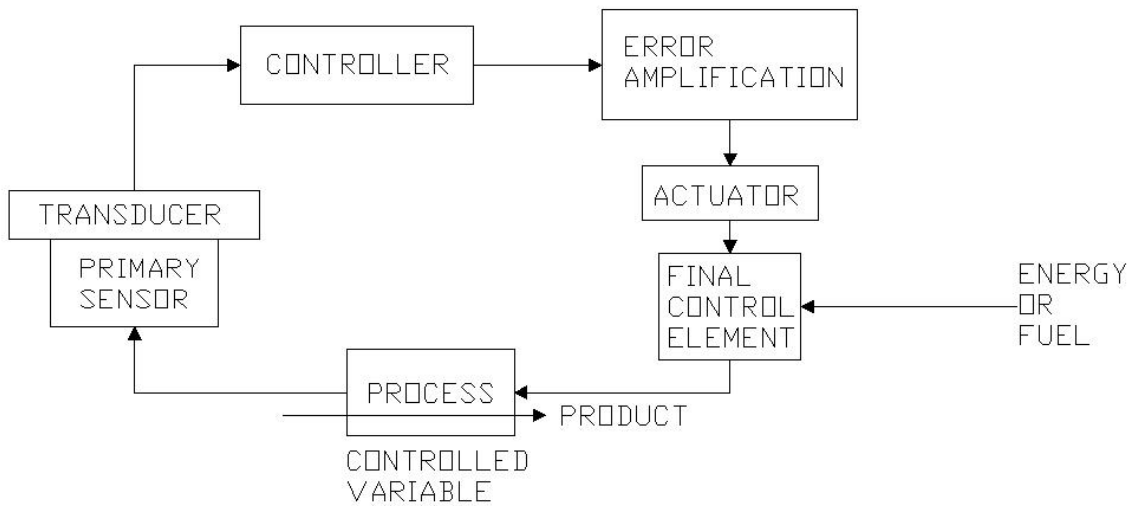

**Figure 2**

# INTRODUCTION OF CONTROL AND INSTRUMENTATION

## Elements of a Control Loop

### Process:

The controlled system is called the process. It could be defined as a conditioned situation that produces results which must be kept under an expected value or range of values. As in Figure 2, the process deals directly with the product. Product in this case could be taken as a material, fluid, or whatever is produced, manufactured, or treated.

### Primary Sensor:

The primary sensor is normally an instrument that has properties to detect the physical property desired to be measured. An example is a thermocouple which produces a change in an electrical circuit proportional to the temperature; this signal is sent to a transducer to be detected and interpreted.

### Transducer:

The transducer is a device that translates the signal from the sensor into a processed electric signal that can be amplified and used by the controller.

### Set Point:

This is a fixed value that is contained in the controller, set by the operator or by an intelligent algorithm or device. This value is compared to the measured value from the transducer. The difference of this comparison is called the **Error**.

### Controller:

The controller is normally an electrical or electronic device that has the following functions:

- Compares the sensing signal from the transducer to the Set point (at the summation point)
- Produces an Error signal from the comparison
- Processes the error signal:
  - To convert it into an actuation signal
  - To manipulate it to condition it by an algorithm, this algorithm will make it:
    - proportional to the error
    - as a function signal that anticipate changes
    - as a function signal that uses history of changes to apply the correction
    - as a function signal with a combination of the above features.



## INTRODUCTION OF CONTROL AND INSTRUMENTATION

The manipulation of the error signal is processed by a mathematical operator called a control algorithm. An example of an algorithm is the PID or Proportional, Integral, Derivative algorithm. This Algorithm uses:

- the mathematical constant K or proportional multiplier actuating the final control element in a linear way proportional to the value of the error
- the integral operator to produce an actuator signal based on the history of the previous errors
- the derivative operator to produce an actuator signal anticipating the next change based on the slope of the error function

Other algorithms are available easily today in the controllers; an example could be the rate-lag operator which uses a combination of PID elements.

### **Amplifier:**

The amplifier increases the intensity of the signal until it is large enough to be able to be used by the actuator.

### **Actuator:**

It is an electromechanical device that takes the actuation signal and converts it into motion following the actuation signal. This motion could be a position as in the case of a solenoid valve, on or off, or a motion, as in the positioning of a modulating or control valve.

### **Final Control Element:**

It is the element upon which the actuator operates. This device is in contact with the process itself.

An example would be a valve which closes or opens as operated by the actuator and controls in such a way the flow of a process, liquid, or gas.

# INTRODUCTION OF CONTROL AND INSTRUMENTATION

## PRIMARY SENSORS

Primary sensors detect the variable to be measured. The following sensing instruments will be presented in this portion of the course:

- Pressure
- Temperature
- Level
- Flow

## Instrument Characteristics

The following table presents the most important general characteristics of instruments and their commonly accepted definitions

<b>Characteristics</b>	
<i>Static</i>	<i>Dynamic</i>
Applicable to variables that are not changing	Apply when variables are changing
<p><i>Accuracy:</i> Is the instrument characteristic or capability to present the real or actual measured variable? If applied to a control system: it is the capability of the control system to maintain the actual measured value during the control process</p> <p><i>Static error:</i> The difference between the actual or true value and the measured or indicated value Static error in a control system refers to the deviation from the desired control value contributed by the control system</p>	<p><i>Fidelity</i> is the capability of the instrument to correctly indicate or record a change in a measured variable? For a control system, it is the ability of the controller to follow the changes in the input variable with the correct output signal <i>Dynamic error</i> is the deviation of the controller output from its correct value</p>
<p><i>Reproductivity</i></p> <ul style="list-style-type: none"> <li>• The ability of the instrument to produce identical values of the same measured variable when the measured value is the same under the same previous conditions</li> <li>• A displacement from the same previous value is called <i>drift</i></li> </ul>	<p><i>Responsiveness</i></p> <ul style="list-style-type: none"> <li>• is characteristic of the instrument to follow variable changes</li> </ul> <p><i>Measuring lag</i></p> <ul style="list-style-type: none"> <li>• is the measured inability of the instrument to follow a variable change?</li> <li>• the measured duration of this lag is called <i>dead time</i></li> </ul>

## INTRODUCTION OF CONTROL AND INSTRUMENTATION

Characteristics	
<i>Static</i>	<i>Dynamic</i>
<p><i>Sensitivity</i> is the magnitude of the smallest value that an instrument can measure?</p> <p><i>Dead Zone</i> For instrumentation, it is the range where the instrument cannot measure For control systems, it is the area of control where the system cannot respond</p>	

Table 2

### PRESSURE

#### Definition

Pressure is a physical function of force and surface. The mathematical definition of pressure is  $F/A$  where  $F$  is force and  $A$  is area.

Mathematically:

$$P = \frac{F}{A}$$

Force is an action that causes distortion or movement.

Surface is a section of the two-dimensional presentation of space.

Other expressions of pressure:

Hydraulic pressure in a press or tank: It can be expressed in water column height, mercury column height, psi, etc. This pressure is due to the weight of the mass of water plus the weight of the mass of air on the water surface. It has been found that the pressure of a liquid can be expressed as a function of the height of the column of liquid.

These expressions of pressure are based on experimental observations as well as calculations and deductions using physical laws. The equivalence of these measurements can be also be performed using dimensional analysis.

To demonstrate the above concepts, we will use the case of the column of water pressure measurement.

See Figure 3 for reference to the following calculations.

## INTRODUCTION OF CONTROL AND INSTRUMENTATION

One of the characteristics of matter is density. It is defined by the ratio between mass and volume that it occupies. Water density has been given the value of 1.

The relation that expresses density is:

$$\rho = \frac{\text{Mass}}{\text{Volume}} = 1 \text{ for water}$$

For specific density, we can replace mass by weight and the equation becomes:

$$sd = \frac{\text{Weight}}{\text{Volume}} = 1 \text{ for water}$$

$$\text{weight} = sd(\text{Volume})$$

$$P = \frac{F}{A} = \frac{\text{Weight}}{A} = \frac{sd(\text{Volume})}{A}$$

But Volume = Area times height or

$$P = \frac{sd(Ah)}{A} = (sd) h, \text{ since for water } sd = 1$$

$P = h$  for water.

The pressure exerted by the water column represented in Figure 3 is the height of the water column (A to B). For another fluid, its P is AB times the fluid specific density.

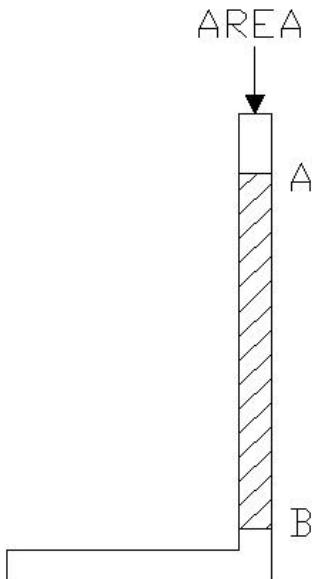

Figure 3– Pressure vessel

# INTRODUCTION OF CONTROL AND INSTRUMENTATION

## Atmospheric Pressure

The column of atmospheric air has weight. Air applies pressure everywhere on earth that is exposed to the atmosphere. Because pressure depends on the height of column of fluid, atmospheric pressure is smaller at higher altitudes. This property is the basis of earlier altitude instruments. Also, water will boil using less heat at a higher altitude. Water will boil at a lower temperature in Mexico City than in New York City.

To measure atmospheric pressure:

- Fill the bottom sealed tube with mercury
- Seal the other end of the tube with your finger
- Turn the tube upside down
- Submerge the end sealed with the finger inside a tank containing mercury
- Let go of the finger as soon as the tube is vertical position
- Measure the height of the mercury column in inches, it is the atmospheric pressure given in inches of mercury

## Gauge, Absolute and Differential Pressure

Pressure can be expressed as gauge, differential and absolute pressure. **Gauge pressure** is the pressure that results of subtracting the atmospheric pressure from the pressure true value or Absolute Pressure. **Absolute pressure** is the true pressure measuring it in reference to zero pressure or vacuum. **Differential pressure** is the pressure of a system compared to the pressure of another system.

## Other pressure units

Pascal:

The Pascal is the SI (The International System of Units, abbreviated SI from the French Le Système International d'Unités pressure measurement).

The dimensional analyses is:

$$P = \frac{F}{A}$$

Force is given in newton and the area in square meter or a pascal is equal to 1 newton force per square meter area.

Pascal is used in metrology expressed in a larger unit multiplied hundred times or hectopascal.

1 hectopascal or hpa is equal to 100 pascal or 100 pa. As a physics reminder: 1 newton is the force that accelerates the mass of one kilogram to one meter per second.

When the height of the column of mercury is measured, the value is 29.9 in. at sea level. This pressure is indicated as 29.9 in of mercury.

These units are equivalent to 14.7 psi or pounds per square inch = 1 atmosphere (atm) = 101.3 kPa (kilopascals) = 14.7 psi (pounds per square inch) = 760 torr.

## INTRODUCTION OF CONTROL AND INSTRUMENTATION

### Pressure Sensors

Instrument	Description	Application
Manometer	<ul style="list-style-type: none"> <li>• It is a U tube that contains a liquid. Levels at both sides are equal.</li> <li>• One end of the tube is then closed; the other end is left open.</li> <li>• The pressure to be measured is applied to the open end.</li> <li>• The level will rise on the closed end and it will sink in the open end.</li> <li>• The pressure is given by the difference in the levels.</li> </ul>	<ul style="list-style-type: none"> <li>• Measurement of pressure in liquid and gases</li> <li>• Blood pressure measurements.</li> <li>• <b>See Figure 4</b></li> </ul>
Bourdon-tube	<ul style="list-style-type: none"> <li>• It is a mechanical instrument that senses pressure and converts it to displacement</li> <li>• The pressure indication is mechanically amplified using a pointer or indicator needle</li> <li>• The Bourdon-tube displacement is a function of the pressure applied</li> <li>• A set of two bourdon tubes mounted in one case is called a duplex gauge</li> </ul>	<ul style="list-style-type: none"> <li>• Many industrial applications for fluid and gas pressures</li> <li>• Hydraulic systems (hydraulic gauges)</li> <li>• Low-pressure Bourdon tubes (pressures up to 2000 psi) are often made of bronze.</li> <li>• High-pressure Bourdon tubes (pressures above 2000 psi) are made of stainless steel or other high-strength materials</li> </ul>
Bellows Elastic Elements - Helical	<ul style="list-style-type: none"> <li>• A bellows elastic element is a convoluted unit</li> <li>• It expands and contracts axially with changes in pressure.</li> </ul> <p>The pressure to be measured can be applied to either the outside or the inside of the bellows</p>	<ul style="list-style-type: none"> <li>• Used mostly for hydraulic fluid measurements.</li> </ul> <p>See Figure 5 - Bourdon Tube Manometer and Figure 6 - Helical Bourdon Pressure Instrument for its components</p>

## INTRODUCTION OF CONTROL AND INSTRUMENTATION

Instrument	Description	Application
Simple Bellows Element	<ul style="list-style-type: none"> <li>• Bellows elastic elements are made of brass, bronze, stainless steel, beryllium-copper, or other metal</li> <li>• Motion of the element (bellows) is transmitted by suitable linkage and gears to a dial pointer.</li> <li>• Most bellows gauges are spring-loaded with a spring that opposes the bellows force and prevents full expansion of the bellows.</li> </ul>	The principle used in this instrument can be used also to measure differential pressure. In this case, there are two bellows chambers with mechanisms that subtract the two pressure produced movements.
Pressure Switches	To determine specific pressures, such as a high or low pressure, pressure switches are used to activate a signal that is sent to the monitoring and alarm systems.	Single pole single throw switches are frequently used for these applications. Electronic switches are also used in newer devices. See <b>Figure 8</b> .

Table 3

### Pressure Instrument Calibration

The calibration of a pressure instrument has been traditionally done using a method called the dead weight calibration.

A typical test set-up is shown in Figure 9.

The setup works in the following manner:

Step	Procedure
1	Load the measuring piston with calibrated weights
2	Add or retrieve load until the loaded measuring piston rises and appears to float on the fluid
3	Calculate the pressure using the formula $P = \frac{F}{A}$
4	Use the weights as the force and the area of the piston as the A

Table 4

Pressure Instruments Figures

Figure 4 – U-Tube Manometer

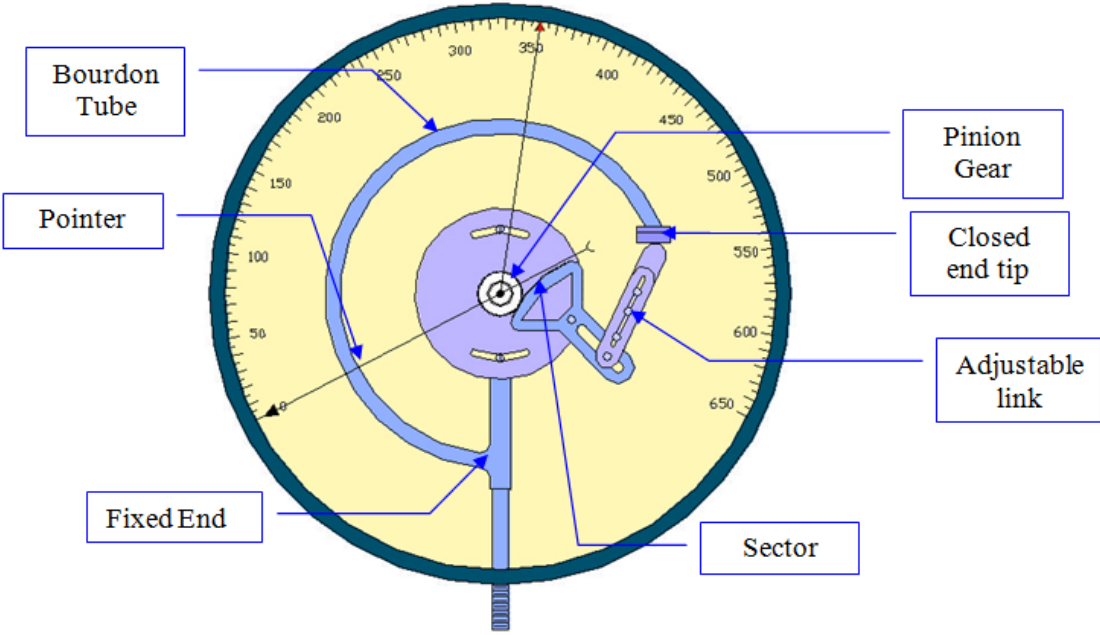
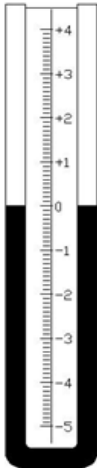

Figure 5 - Bourdon Tube Manometer



# INTRODUCTION OF CONTROL AND INSTRUMENTATION

Figure 6 - Helical Bourdon Pressure Instrument

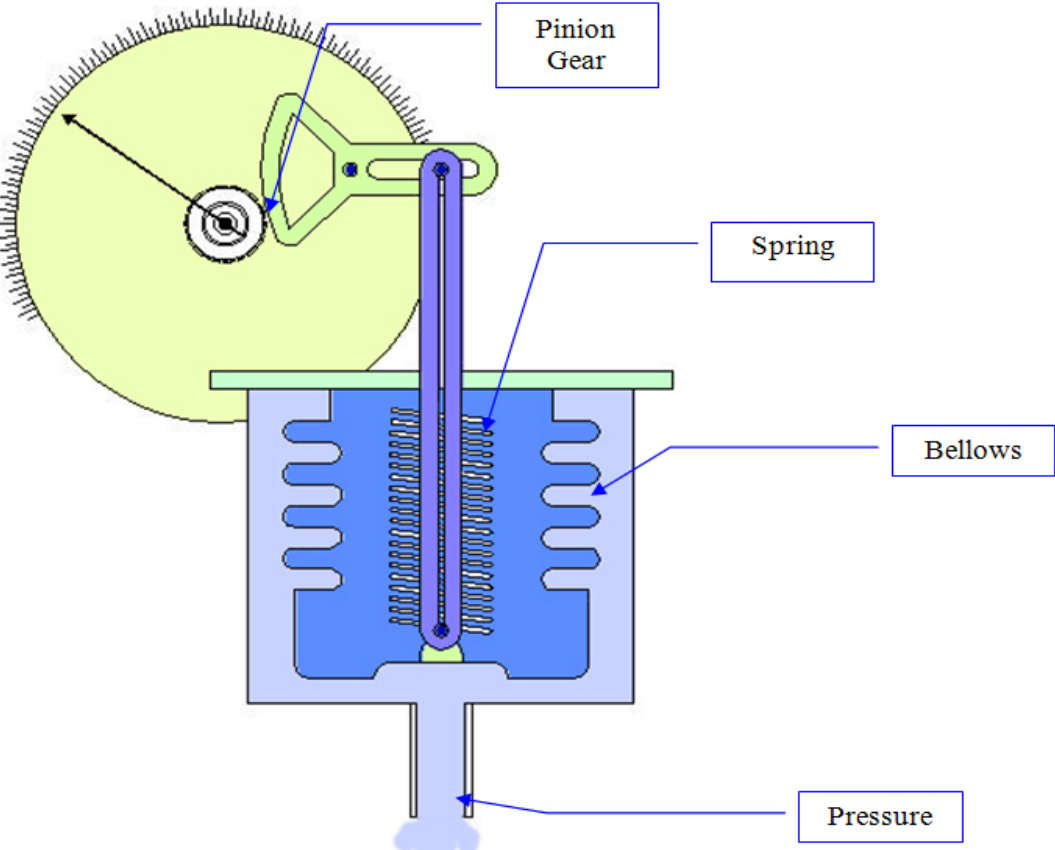
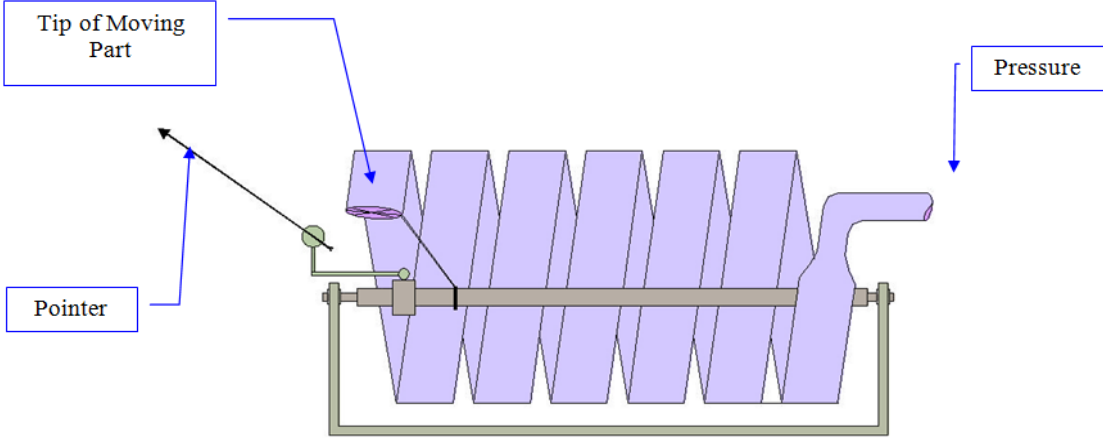

Figure 7 – Simple Bellows Gauge

# INTRODUCTION OF CONTROL AND INSTRUMENTATION

Figure 8 - Pressure Switch Housing

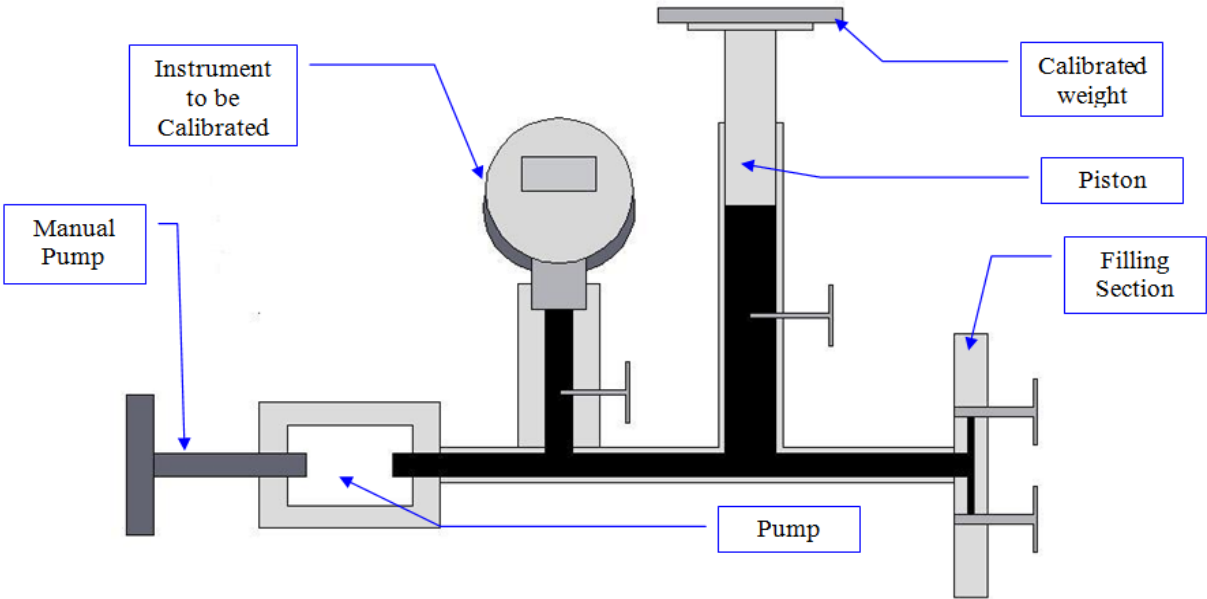
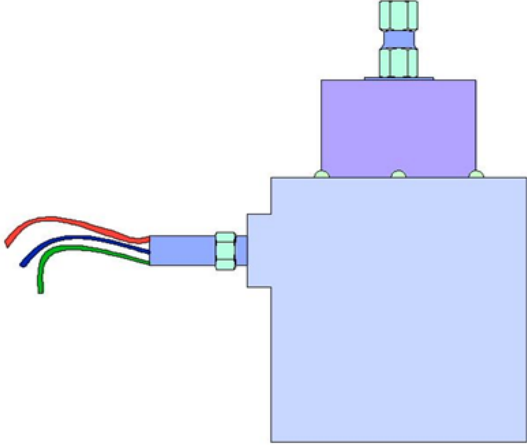

Figure 9 - Dead Weight test set up

# INTRODUCTION OF CONTROL AND INSTRUMENTATION

## Temperature

This section will present the basic concepts of temperature, its measurements, and techniques. Definitions and a small section of the physics of temperature will begin the section; later a presentation of the most commonly used temperature sensors and transducers will be outlined including reference material for practical engineering use.

### Definitions

Temperature is defined as the degree of heat or cold that an element exhibits. This concept comes from practical evaluation of the thermal behavior of substances, most commonly water.

A more sophisticated definition would be: the measurement of temperature is the measurement of the average thermal energy per molecule contained in a material. The unit used to describe the thermal energy per molecule of a certain material is the degree of temperature. These units are arranged in a scale called the temperature scales. An important place to calibrate a temperature scale is a point of equilibrium thermal equilibrium in the substance. This point is seen as a temperature in which the substance remains at an equilibrium, (ie. ice and water mixture or water and steam).

In water, there are several points of thermal equilibrium at a given pressure.

The most notable point for water is the point in which solid, liquid, and gas are at equilibrium (triple point). This point exists at normal atmospheric pressure of one atmosphere and it is the zero-degree point for the Celsius thermal scale.

Another point of the scale calibration could be found at the point where liquid and gas water are at equilibrium at one atmosphere. This point was arbitrarily given the value of 100 on the Celsius scale. Then the scale was built dividing it into 100 equal divisions. Other scales use other equilibrium points; the Fahrenheit scale uses a zero point as the point where a mixture of salt (NaCl) and water allows the existence of liquid and solid water to remain at equilibrium.

The relations shown below can help to convert Celsius to Fahrenheit and Fahrenheit to Celsius

$$C = \frac{5}{9} (F-32)$$

$$F = \frac{9}{5} C + 32$$

# INTRODUCTION OF CONTROL AND INSTRUMENTATION

## Temperature Sensors

Temperature is measured using the fact that when exposed to temperature changes, some materials change. Some changes are changes in physical properties and physical dimensions.

There many types of change that are related to thermal variations such as:

- Length
- Electrical properties
- Energy

### Length

Some metals change in length of as well as expand and contract when subjected to temperature changes. These changes are used to design temperature sensors.

### Electrical

#### *Generation*

When temperature changes are applied to two different materials in physical contact, there is a migration of electrons from one of the materials to the other due to the difference of each material's electrochemical properties. This effect is used in thermocouples.

#### *Resistance*

Because resistance is a thermal property of materials (discovered by Joule), it would be expected that a change in temperature would produce a change in resistance; this is used by RTDs.

### Energy

#### *Infrared*

Infrared temperature measurement is used to measure temperature in radiating bodies and at a distance. Such measurement could be the temperature of an oven or the temperature of a remote hot object. The explanation of this method of temperature measurement uses quantum mechanics starting with Plank's radiation law.

## Temperature Sensors – Length Based

The most commonly used sensor based on length changes is the bimetallic sensor. Its importance is due to its practical use and price. Bimetallic sensors are used in many electrical applications, including motor overload trip devices and temperature measuring indicators.

## INTRODUCTION OF CONTROL AND INSTRUMENTATION

A metal exposed to heat will expand or contract with heat. The length that a metal will expand at given temperature is different for each metal.

When two strips of different metals are joined together at both ends they will bend as the temperature is increased. One metal will expand more than the other, forcing the pair to bend. The distortion depends on the amount of temperature surrounding the metals. This property can be used to create a thermometer as shown in Figure 10.

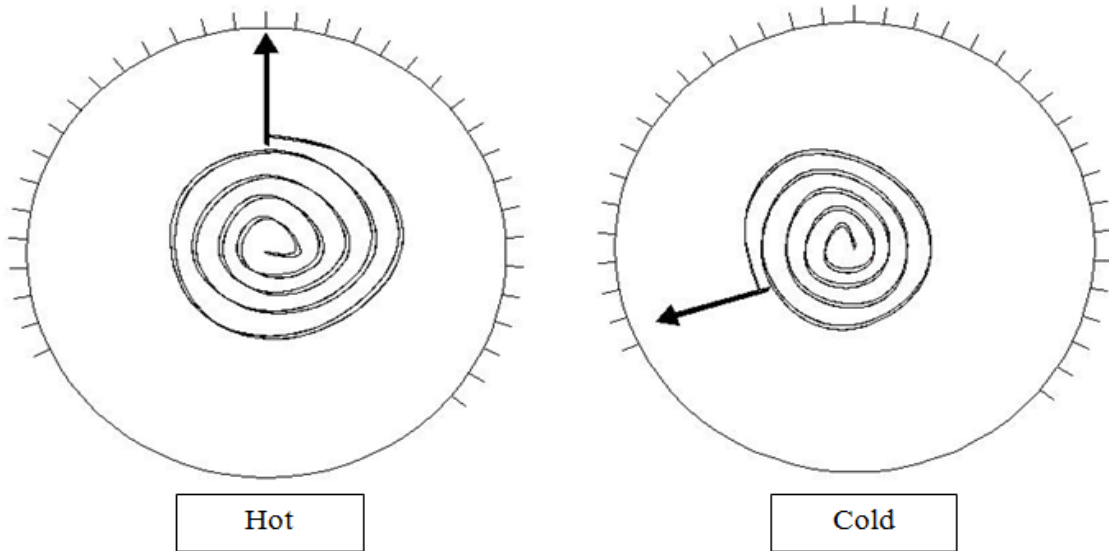

**Figure 10 – Bimetallic Spiral Thermometer**

The instrument shown in Figure 10 is made with a spiral wound bimetallic wire. As the wire gets hot the wire size increases and bends due to the constraint of one metal by the other.

### Electrical Based Temperature Sensors

#### Thermocouples

*Generation* of electricity is a phenomenon that occurs when two dissimilar metals are joined together. Each metal has a different level of energy due to its electronic level. This is referred sometimes as the energy well of the metal.

When two different metals are joined together with a small separation between them, there is a thermos-ionic migration from the metal that has the smallest energy level. This effect is called the tunnel effect and occurs for very small distances, small enough to allow the electronic energy level of each metal superimpose each other.

A distance of  $10^{-7}$  centimeters would allow this effect to happen. A detailed explanation of this effect is beyond the intent of this course.

The previously described effect is called *thermocouple* effect. The increase in temperature will increase the amount of energy in the junction and more current will flow from one metal to the other.

#### Resistance Temperature Detectors or RTD

*Resistance* is always part of a conductor. Heat generated by a conductor by the flow of electrical current is intimately related to resistance. The temperature of a conductor will alter the value of the resistance of the conductor. An RTD is a device that detects temperature based on this property.

Normally a RTD is made with of a fine coil of metal wrapped around a ceramic or glass core. To protect this delicate arrangement, it is placed inside a sturdy probe.

The resistance of the metal used in the RTD is well documented at various temperatures, via testing of the RTD response to various temperatures. Many selected materials have well established and documented change in resistance as the temperature changes.

To measure the temperature using an RTD, use RTD reference tables which are based on specific values of the RTD resistance versus temperature.

RTDs are used when the following important factors are required:

- Accuracy
- Stability
- Repeatability
- Immunity to electrical noise

Additionally, the time response of RTDs is better than other similar thermal instruments used in the same applications, such as thermocouples.

## INTRODUCTION OF CONTROL AND INSTRUMENTATION

Both thermocouples and RTDs are placed in thermowells when the temperature is to be sensed inside a tank or a pipe. See Figure 11 –Thermowell.

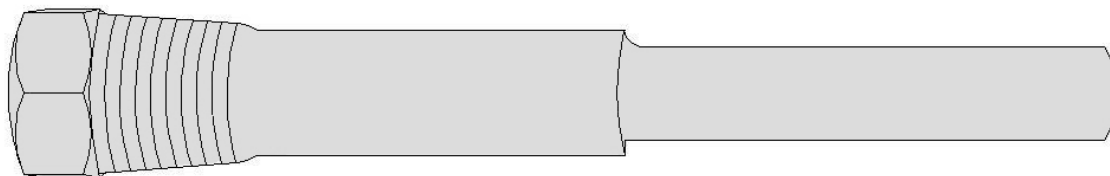

Figure 11 –Thermowell

### Energy Based Sensors

Infrared detection is produced detecting light in the infrared frequency emitted by materials. The detectors use materials that will react to the energy content of infrared waves and their reaction can be quantified and translated into temperatures. In quantum theory, using the Stefan-Boltzmann Law, we can say that the total radiation energy (emitted by the material) is proportional to the fourth power of the absolute temperature. The early twentieth century scientist Wien indicated in his “Displacement Law” that the product of the peak wavelength and the temperature is a numerical constant. He was awarded the Nobel Prize for Physics for the year 1911. This relationship can be used to measure temperatures.

The sensor in an IR (Infra-Red) thermometer collects a small amount of energy (usually 0.0001 watt) radiated from the target, then it generates an electrical signal that is amplified by a sensitive amplifier and converted into voltage output. An analog to digital chip (such as a 16 bit Analog-to-Digital Converter) digitizes the signal sending the signal to an Arithmetic Unit which solves a temperature equation based on Planck’s Radiation Law; it uses an algorithm to compensate for the ambient temperature and emissivity. The result of these manipulations produces a temperature reading.

# INTRODUCTION OF CONTROL AND INSTRUMENTATION

## LEVEL

### Level Sensors

Level measurements are an essential part of modern industry. Tanks containing fluids and solids have their levels continuously monitored to determine the amount of material, to prevent spills or overflow, and to determine the need to add more material.

One way to classify level sensors is by how the measurement is made, either directly or indirectly, depending on the material that is being monitored.

Direct methods are used to measure liquid levels, granular material such as grains, and powder, or flour and salts.

Indirect methods use other physical properties to indirectly determine the level of materials. Among these physical properties are: pressure which could vary with the increase or decrease of material in a container, or weight inside the container.

Another way to classify these instruments is how the sensor senses the material. In this case, the detection could be either continuous detection or a single point detection. The continuous detection sensors detect the level as it changes. This detection method senses the level at a certain specific point. One example would be a low-level point; another point would be a high-level point. This type of sensor is normally a switch or switches located to be activated as the corresponding level is reached.

The following table will present the most common level sensors.

#### Level sensors

Sensor	Type/Description
Floats	This type of sensor is a direct measurement and point detection sensor. Traditionally it has been a floating ball connected to the controller by means of a rod or link, the movement of the ball positions a linked lever that actuates the corresponding switch. More modern units use a floating cylinder containing a ferromagnetic material. See Figure 12. This cylinder slides on a shaft that contains a magnetic link or rod. The link or rod moves as the level varies, the position of a cam on the other end of the link or rod actuates switches mounted in the switching housing.
Pneumatic	This type of sensor is a direct measurement as well as point detection sensor. Pneumatic level sensors are used in hazardous areas, such as those classified as IE by the NEC, or where there is no electric power, and in applications involving material such as sludge. The mechanism of these devices is as follows: When the level of the material changes, it compresses a column of air which is in contact with a diaphragm. This diaphragm actuates a switch, which is in turn is used for determining the level.
Conductivity probes	This type of sensor is a direct measurement and point detection sensor. See Figure 14. Conductive probes use low voltages and currents. The current and voltage in this unit is very small; due to this feature these sensors could be classified according to the NEC as "Intrinsically Safe" since they



## INTRODUCTION OF CONTROL AND INSTRUMENTATION

	<p>cannot sustain ignition.          Conductive sensors are made of solid-state materials.          Some disadvantages are inherent of the units when used to measure materials that can coat the sensor, insulating it, and thus decreasing its conductive sensing capability.          Also, since the signals are very small, a good ground must be present in the probe circuit to isolate noise and other parasitic signals.          The sensor has two electrodes fed by a low voltage, low current signal that establishes a conductivity value. This value is matched to the liquid conductivity. This conductivity in turn is a function of the level. See Figure 14.</p>
Vibrating Level	<p>These sensors use a vibrating device which vibrates at its resonant frequency. When the material contacts the probe, it stops vibrating and the level switch is activated.          There are two common types. The piezoelectric probes and the tuning fork type probe.          This system is used for detection of very fine powders and granular solids. The position of the probes is important to prevent false level detections.</p>
Capacitive	<p>The system uses a capacitive sensing system between the probe and the material of which the level is sought. The circuit uses radio frequency signals. The sensors are designed to sense the dielectric property of the material, dielectric constants as low as 1.1 (ash) and as high as 88 (water) are within the detection range of these systems.          Another use of this system is the detection of the interface between two non-mixing liquids each having a substantially different dielectric constant from the other. The detection of this interface uses a two-probe system.          The capacitance system is sensitive to electrostatic discharges, for this reason as in the conductivity system a good grounding system is required.          See Figure 13.</p>

## INTRODUCTION OF CONTROL AND INSTRUMENTATION

<p>Ultrasonic</p>	<p>Ultrasonic probes are used to measure level at a distance. These instruments are of the non-contact type. The sensor does not need to be in contact with the substance being measured, but it needs a clear view of the surface. Some of the most common applications of these devices are measuring level for corrosive substances, for liquids such as slurries and grease, and waste applications. Also, you will find them measuring levels in grain silos and cement containers. The sensors work by emitting and receiving an ultrasonic frequency signal that is reflected from the surface of the material. The duration of the travel from the sensor and back is calibrated to reflect a distance. This distance is then computed using the dimensions of the system and then expressed as a level. The receiving sensor is usually part of the same housing with the emitter. Some problems are accuracy and repeatability of measurements when humidity changes around the signal. This is because the speed of sound depends on the density of the medium where it is transmitted. The temperature variations also affect the measurement. For these reasons temperature and humidity compensation is sometimes an essential part of this level measuring system.</p>
<p>Radar Level Sensor</p>	<p>Radar transmitters are the logical extension of ultrasonic sensors in applications requiring non-contact measurement of liquid levels. They are the correct application for areas where vapor, dust, or a foaming surface makes ultrasonic measurement inaccurate. Radar sensor uses a microwave pulse to target liquids from the tip of the sensor to the bottom of a tank. This signal is a reliable pulse minimally affected by environmental conditions. See Figure 15.</p>

Table 5

Level Sensor and Transducers Figures

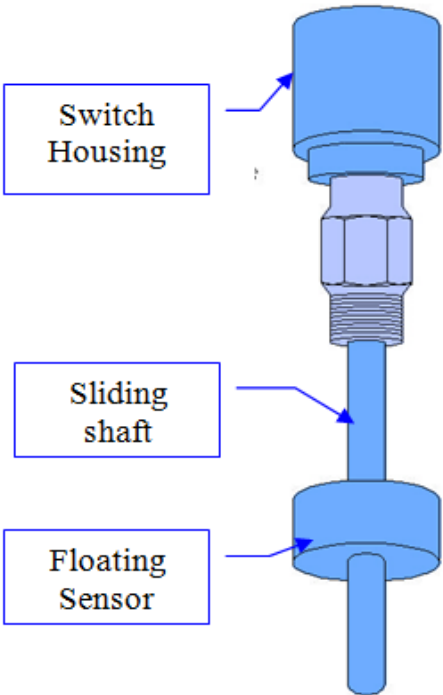

Figure 12 – Float Level Transmitter

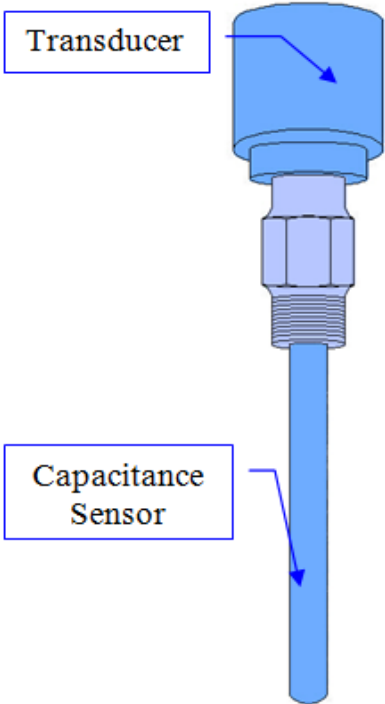

Figure 13 – Capacitance Level Transmitter

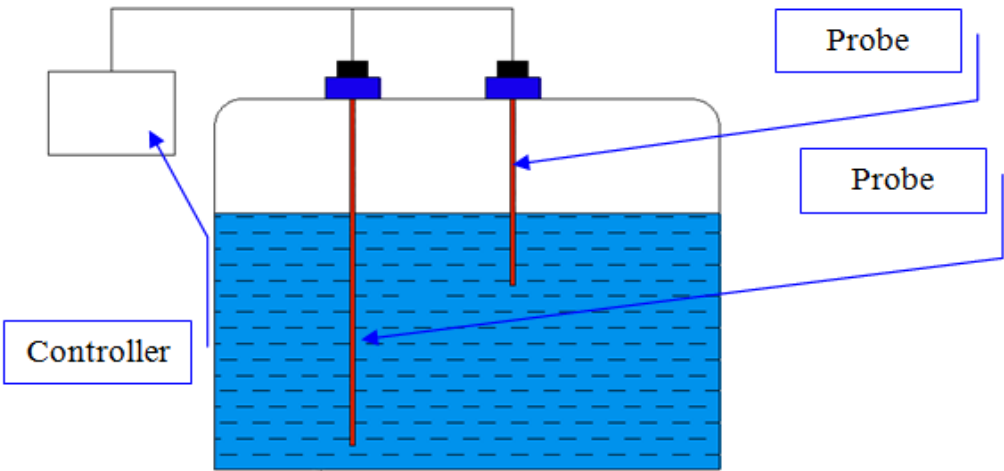

Figure 14 – Conductivity level system

# INTRODUCTION OF CONTROL AND INSTRUMENTATION

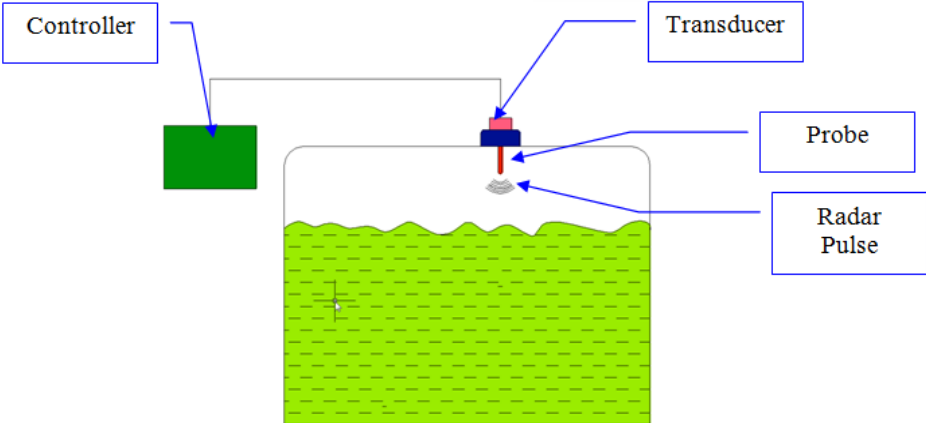

Figure 15 – Radar Instrumentation

# INTRODUCTION OF CONTROL AND INSTRUMENTATION

## FLOW

Flow is the movement of a fluid in a contained path. Flow measurements are normally classified using two features of flow: Flow rate and Total flow.

*Flow rate* is the amount of flow that moves past a certain point per unit time.

*Total Flow* is the amount of flow that passes a given point during a period.

## Flow instruments

Flow instruments are designed to measure either flow rate or total flow. An instrument that can measure a combination is also available.

The following table presents the most common flow instruments:

### Flow Rate Instruments

Instrument	Type and description
<b>Flow Rate</b>	
Differential Pressure	<p>The principle of operation of differential pressure flow meters is based on the property that the pressure drop across the meter is proportional to the square of the flow rate. The mathematical operation to obtain the flow rate is done by measuring the pressure differential and extracting the square root.</p> <p>A DP flow meter is made of two elements:</p> <ul style="list-style-type: none"><li>• Primary element – creates the differential pressure (causing a change in the kinetic energy of the fluid)</li><li>• Secondary element - Measures the DP. The element contains the sensor and transducer that provides the signal or read-out converted to the actual flow value</li></ul> <p>Design considerations:</p> <p>The unit must be properly matched to:</p> <ul style="list-style-type: none"><li>• the pipe size</li><li>• flow conditions</li><li>• the liquid's properties</li></ul>

## INTRODUCTION OF CONTROL AND INSTRUMENTATION

<p>Differential pressure Primary elements:</p> <p><i>Orifice Plates</i></p>	<p>The orifice plate is a flat piece of metal that has an orifice or hole drilled or cut in it. The orifice is usually circular or concentric to the pipe but other shapes are also used. Installation is made locating the plate between two flanges.</p> <p>The orifice plate, by constraining the surface, reduces the flow, and increases the velocity of the fluid, creating a different pressure at the exit of the fluid than at the inlet. Thus, there is a differential pressure across the plate.</p> <p>A pressure measurement on both sides of the plate is made and the differential pressure used to calculate the flow rate as indicated above.</p> <p>One disadvantage of the orifice plate is that it adds losses to the flow because it restricts the flow which in turn, due to friction, adds resistance to the fluid flow.</p> <div style="text-align: center;">  </div> <p><b>Figure 16 – Orifice Plate</b></p>
<p>Differential pressure Primary elements:</p> <p><i>Ventury Tube</i></p>	<p>A Venturi tube uses the same principle of the orifice plate. The fluid is constricted while passing through a reduced diameter flow way.</p> <p>The difference is that the device instead of being a plate with a hole is a section of pipe with a tapered entrance and a straight throat. See Figure 17.</p> <p>These sensors do not have moving parts and they are more accurate, although considerably more expensive.</p> <div style="text-align: center;">  </div> <p><b>Figure 17 – Venturi Tube</b></p>

Table 6

**Differential pressure  
Primary elements:**

The flow nozzle is an intermediate step between the orifice plate and the Venturi Tube. It looks very like the Venturi Tube and resembles half of a Venturi Tube.

## INTRODUCTION OF CONTROL AND INSTRUMENTATION

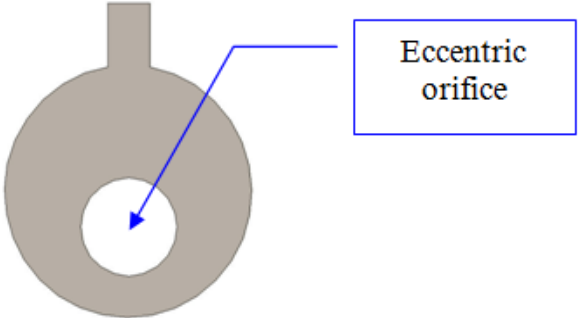
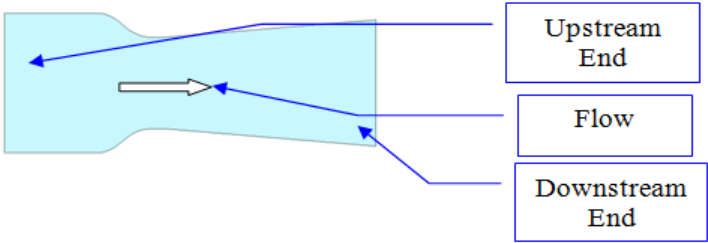
### *Flow Nozzle*

The cost is less than a Venturi Tube but its accuracy is almost as much as the Venturi Tube

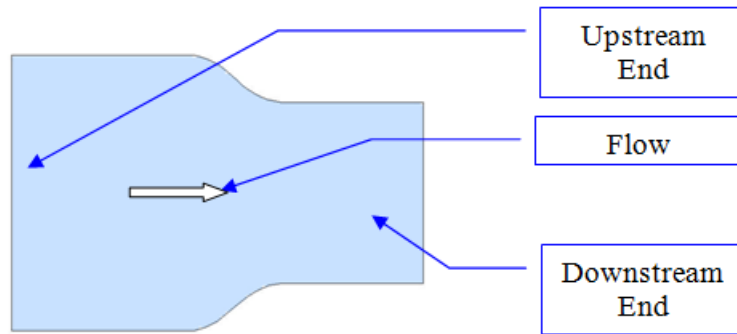

**Figure 18 – Flow Nozzle**

### **Location of the pressure taps**

Pressure taps to measure differential pressure are located at a distance from each other to be able to detect the pressure at the normal flow and the pressure after the constriction.

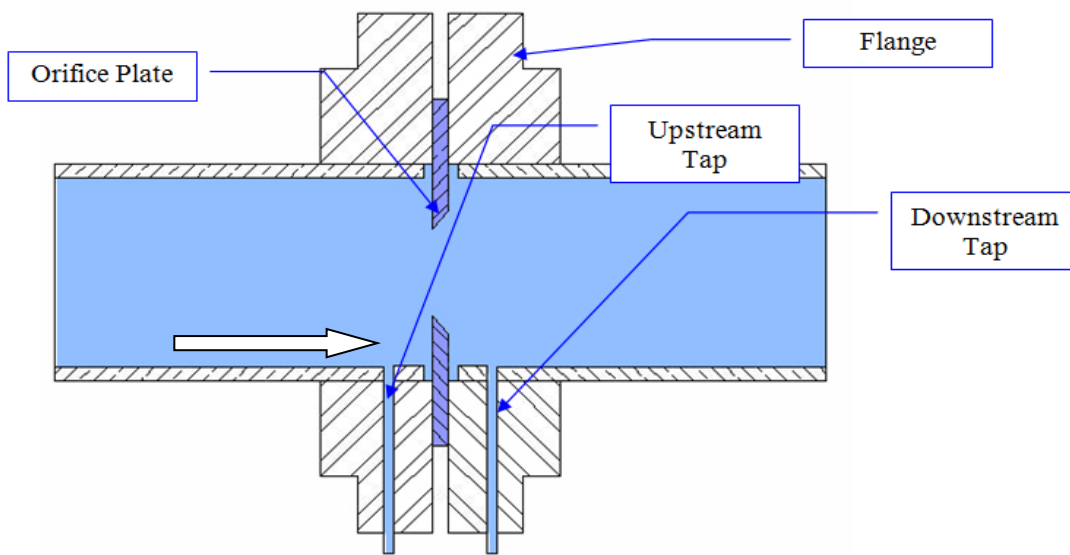

**Figure 19 – Pressure tube location for DP measurements**

# INTRODUCTION OF CONTROL AND INSTRUMENTATION

## Other Methods for Measuring Flow Rate

There are other methods to measure flow that are also used for conditions that do not require the same accuracy as that obtained by the differential pressure methods.

- Rotameter – The pipe area is varied using an inside float. The pipe at this point is vertical and the float moves along a scale calibrated in flow rate units. It is used for measuring the flow in gases and liquids
- Open channel methods: Weir, flumes, open nozzles

## Total Flow Instruments

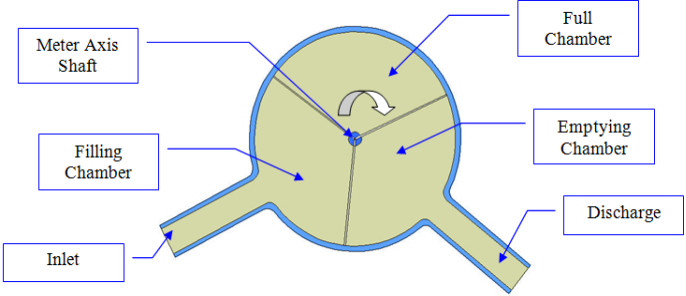
Instrument	Type and description
<b>Total Flow</b>	
Positive displacement	<p>This method uses a counting technique to measure the flow. The system consists of:</p> <ul style="list-style-type: none"> <li>• Chambers (three in the figure) in which the fluid enters.</li> <li>• Rotating elements (also three in the figure) and shaft</li> </ul> <p>As one chamber charges and discharges with the flow, this event is counted as one count. The calculations must consider the volume of the chamber. Each time a chamber is filled determines a volume of fluid that has moved along the pipe. The number of times the chamber is filled multiplied by the volume is divided by unit time to determine the total flow.</p> <div style="text-align: center;">  <p>The diagram illustrates a positive displacement flow meter. It features a central 'Meter Axis Shaft' that rotates three chambers: a 'Full Chamber' at the top, an 'Emptying Chamber' on the right, and a 'Filling Chamber' on the left. An 'Inlet' pipe enters from the bottom left, and a 'Discharge' pipe exits from the bottom right. Arrows indicate the flow direction and the rotation of the shaft.</p> </div> <p style="text-align: center;"><b>Figure 20 – Positive displacement flow meter</b></p>



# INTRODUCTION OF CONTROL AND INSTRUMENTATION

Instrument	Type and description
Ultrasonic Measurement	<p style="text-align: center;"><b>Total Flow</b></p> <p>This method uses modern technology and its accuracy is high. The set up involves two probes located in the path of the flow. The figure below shows one type of installation.</p> <div style="text-align: center;">  <p>The diagram shows a blue cylindrical pipe with a white arrow indicating flow direction. Two probes, labeled 'Probe A' and 'Probe B', are mounted on the pipe. A green rectangular box labeled 'Transducer Reader' is connected to both probes by thin lines. A dashed blue line with arrows indicates the path of an ultrasonic wave from Probe A to Probe B.</p> </div> <p><b>Figure 21 – Ultrasonic Flow Generic Probe Locations</b>            In the figure below, the flow is measured by sending an ultrasonic wave at point A and receiving it at point B. The duration of the wave from A to B determines the flow. The unit is calibrated at zero flow to establish speed and duration of wave at rest.</p> <div style="text-align: center;">  <p>The diagram shows a cross-section of a pipe with a blue fluid flowing from left to right, indicated by a white arrow. Two probes, labeled 'Probe A' and 'Probe B', are mounted on the top and bottom walls of the pipe, respectively. Blue lines with arrows point from the labels to the probes.</p> </div> <p><b>Figure 22 – Location of Ultrasonic Probes</b>            This installation measures the flow comparing the travel time of the sound wave towards and against the flow and comparing the difference in speed.</p>

Table 7

# INTRODUCTION OF CONTROL AND INSTRUMENTATION

## MOTOR CONTROLS

### Introduction

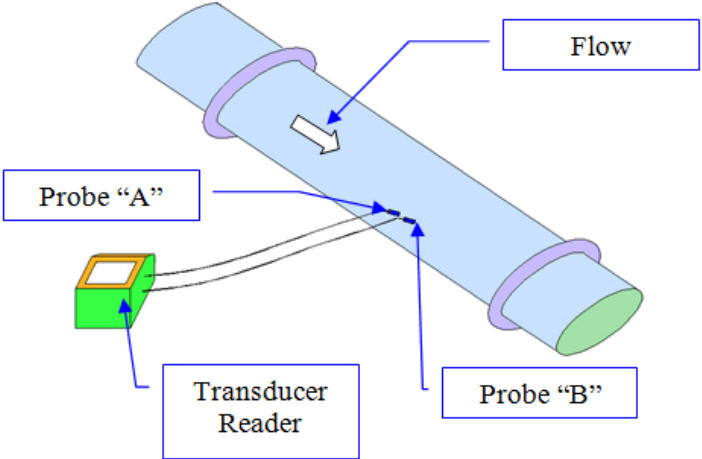
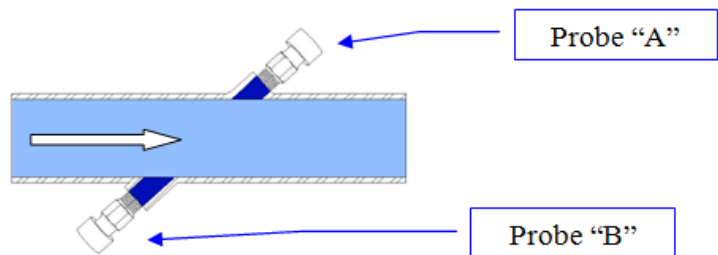
Motor Control is an area of control systems that pertains to the control of the most used motion actuator in industry: the electric motor. The electrical circuit connecting motors includes a power source and protection, and a manual starter with the overheat protection; the latter is part of the motor control.

Today, due to the advances of motor control technology, the motor is controlled automatically. The motor control includes a sophisticated algorithm that can make changes of speed and direction to the motor using ramping speeds and accelerations. Motors also have changed; the improvement in windings and copper alloys has made possible a smaller motor which can produce the same power output as the old larger one. These new motors are (if designed so) capable of sustaining harmonics and other non-sinusoidal feed signals.

### Motor Controllers

A motor controller consists of a group of devices that govern, regulate, and energize or de-energize a motor.

The functions of a motor controller include:

- Starting
- Stopping
- Accelerating
- Reversing
- Protecting

There are two major types of motor controllers:

- Manual
- Automatic

A manual controller is as the name indicates: one in which the motor is being controlled by hand. Many systems still have manual controllers even if the motor is controlled automatically. The reason behind keeping a manual control is first for safety and second for maintenance of the motor or machine.

## INTRODUCTION OF CONTROL AND INSTRUMENTATION

Most automatic controls performed today use two basically different methods:

- Relay logic
- Programmable equipment:
  - Programmable Logic Devices (PLC)
  - DCS equipment (computer system)

A typical manual controller diagram is shown in Figure 23 – Motor Manual Control below:

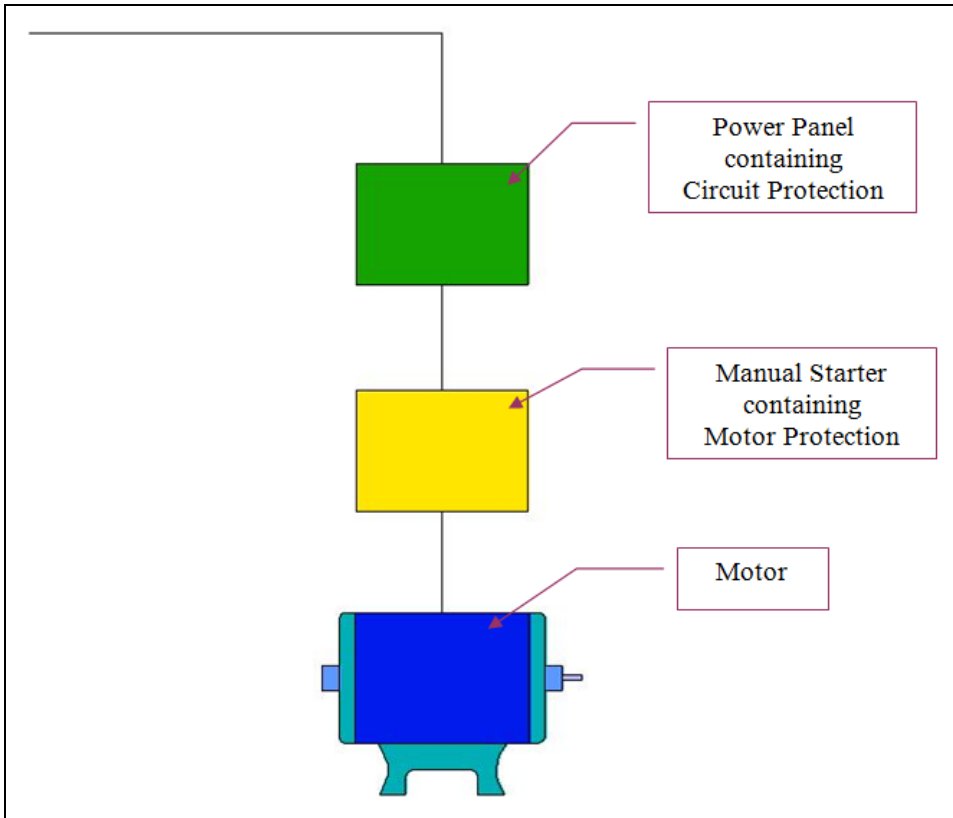

**Figure 23 – Motor Manual Control**

The National Electrical Code regulates the design of the circuit that controls a motor. The rules in this code are designed to protect the public and equipment. It will protect primarily against fires but also against other electrical hazards. Additionally, to prevent a motor from extreme overheating, a means of protecting it from overcurrent (overload, short circuit, or ground fault) must be provided.

In Figure 24 – Motor Electrical Control Connection. The power and control connections are shown in a schematic manner. The elements of this diagram show that power is connected to the motor via a controller. The controller will energize the motor and supply the power waveform if the controller has the capability to change the feeding power wave. Devices such as AC drives are designed to manipulate the incoming power wave and convert it in a power waveform of different frequency. This new power supplied to the motor will be able to rotate the motor at a different speed.

## INTRODUCTION OF CONTROL AND INSTRUMENTATION

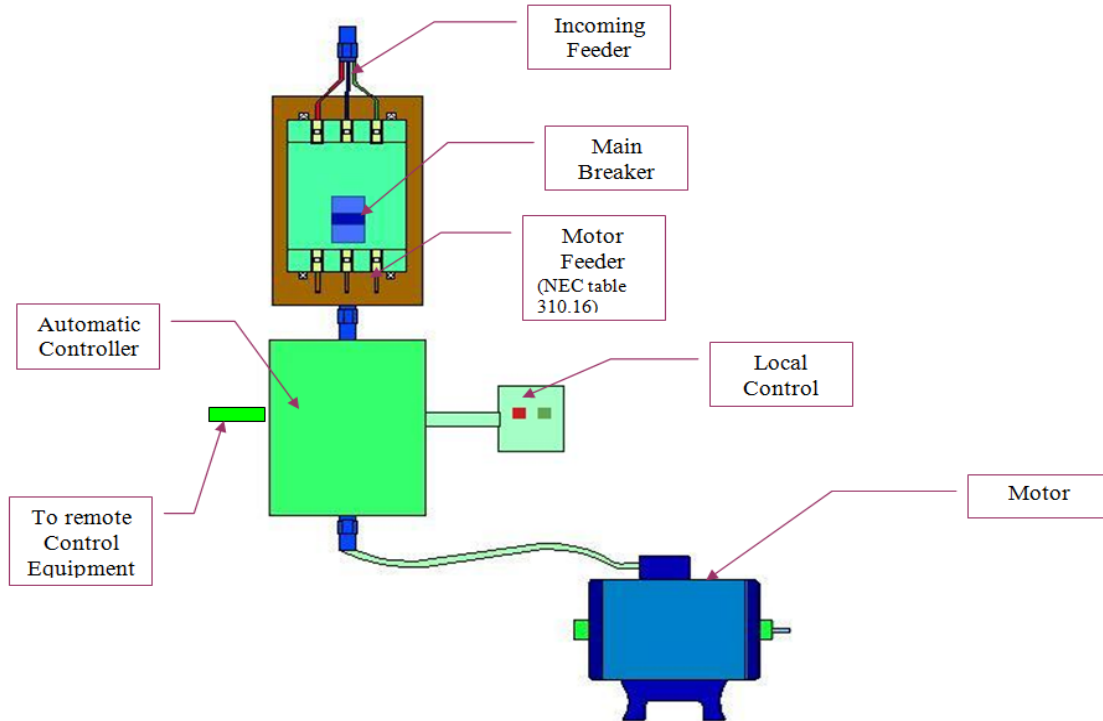

Figure 24 – Motor Electrical Control Connection

### Motor Control Elements

The following table lists and describes the basic elements of motor control:

Motor Control	Function
Starter	Starter is the part of the control system that initiates the motor function. It contains the electromechanical components that permit electric current to reach the motor windings.
Overload Relays	Overload relays are protection elements against an over temperature in the motor that can cause motor failures due to overheating.

## INTRODUCTION OF CONTROL AND INSTRUMENTATION

Control Stations	Operate the motor starter remotely. They also function as safety stopping stations (E Stops).
Relays and Contactors	Elements that interlock permissive conditions to the motor running or stopping. Contactors are the large control components that allow motor current to be supplied to the motor. Relay contacts normally activate contactor coils.
Remote Actuators	Permissive contacts that are included in the control logic that provide the desired conditions to the motor to run or to stop. Such components could be limit switches, level switches or other switch or contacts.

Table 8

### Starters

There also are two main types of starters:

- Manual
- Automatic

#### Manual Starters

These starters supply the simplest way to start a motor. They are usually toggle switches with an overload element connected in series with the contacts.

The motor wires are connected directly to the starter. Schematic of this connection is shown below:

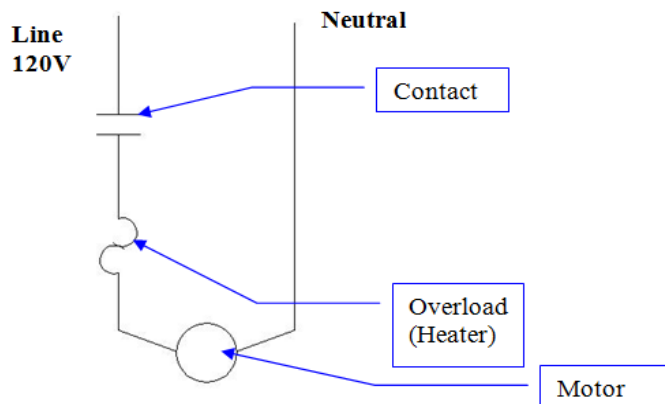

Figure 25 – Motor Manual Control Schematic

## INTRODUCTION OF CONTROL AND INSTRUMENTATION

Application of manual motor starters is usually applied to small motor controls. Motors called fractional motors are in this type of application. The term fractional refers to motor with horsepower ratings smaller than unity. However, fractional motors also include motors. Wound field designs include motors through 3 HP and permanent magnet designs through 5 HP.

### Automatic starters

The most common mode of controlling motors in industrial environments is the automatic system.

Earlier automatic systems relied on relay logic to control the starting and stopping of motors. More modern methods include Programmable Logic Controllers (PLC) and DCS systems that consist of computer systems and a software program to execute the logic. An intermediate system was available for a short time in which the logic was programmed using hardware programming and OP Amp (Operational Amplifiers) to program the logic in the system. This system is not very common.

### Relay Logic

Relay logic is used to control the motor using relays and their contact arranged in a structure called ladder programming.

A simple control using relay logic includes the starting motor coil (contactor or starter coil) a light to indicate the motor running, motor protection (thermal element) and the contacts from the contactor. This motor can be started either automatically by moving the selector switch to Automatic and starting by the action of the limit switch; or by moving the switch to selector switch to Manual. The “C” contacts in a motor control schematic (also sometimes shown as “M” contacts) are contacts from the main contactor of the motor circuit. These contacts allow the voltage to be applied to the motor control circuits and to the motor.

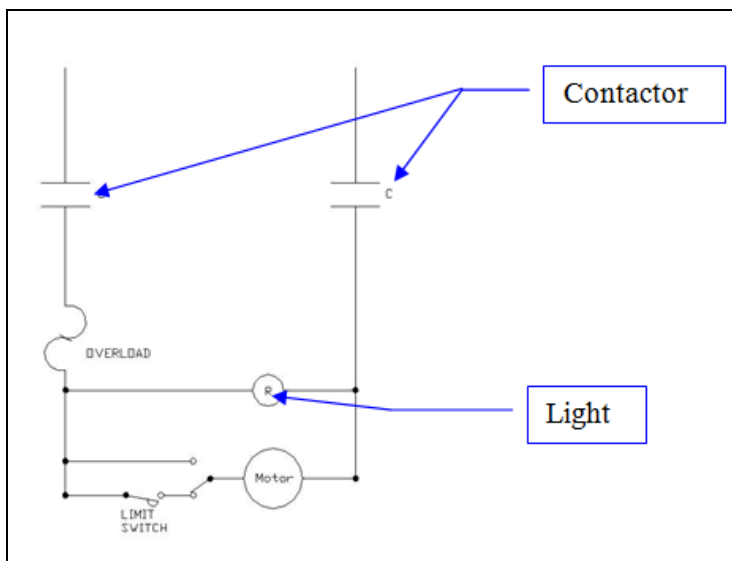

Figure 26 – Auto-Manual Motor Control

## INTRODUCTION OF CONTROL AND INSTRUMENTATION

Relay logic, three-phase motor starting circuit is presented below in Table 9 – Motor control components. Also see Figure 27 – Basic Automatic Motor Starting and Control Circuit.

Component	Function
Stop push button	Opens the circuit branch that feeds the motor operating control coil (M), disconnecting the motor from the supply voltage
Start Push button	Closes the branch that energizes the motor operating control coil allowing the contacts to close and thus allows voltage to be applied across the motor
Starting coil	Is the motor operating control coil and acts as the primary auxiliary control device
Auxiliary starting coil contacts	Contacts from the starting coil. One of them is the <i>seal in contact</i> . This contact maintains the coil energized after starting.
Three Phase circuit feeder	Power conductors that energize the motor and the control circuit
Control Transformer	Transforms supply power voltage to control power voltage
Circuit protection	There are two protection sets: one that is connected immediately after the main switch and the other before the control transformer feed

**Table 9 – Motor control components**

The relay coils and contacts are arranged in rungs. Similar to the rungs of a ladder. This type of arrangement is called ladder programming. In the case shown in the schematics below, the ladder programming is made using relays; therefore, the motor control using this technology is called relay logic.

When the programming uses an electronic device such as a computer based unit (PLC), the ladder is made in a virtual manner. This means that the relays and contacts are logic conditions that are established using computer logic. The final conditions to be produced or received as permissives in the logic are interfaced with the motor or real world device using input or output cards. The signals or conditions going or coming from the program to the real world are called inputs and outputs. The interface with the computer is made using hardware such as cards that contains micro relays and logic chips that can talk to both the computer hardware and to the relays or instrumentation in the field. All these software operations are performed using a PLC usually installed inside a cabinet of a unit in the MCC or Motor Control Center.

The organization of these MCCs is further discussed below.

## INTRODUCTION OF CONTROL AND INSTRUMENTATION

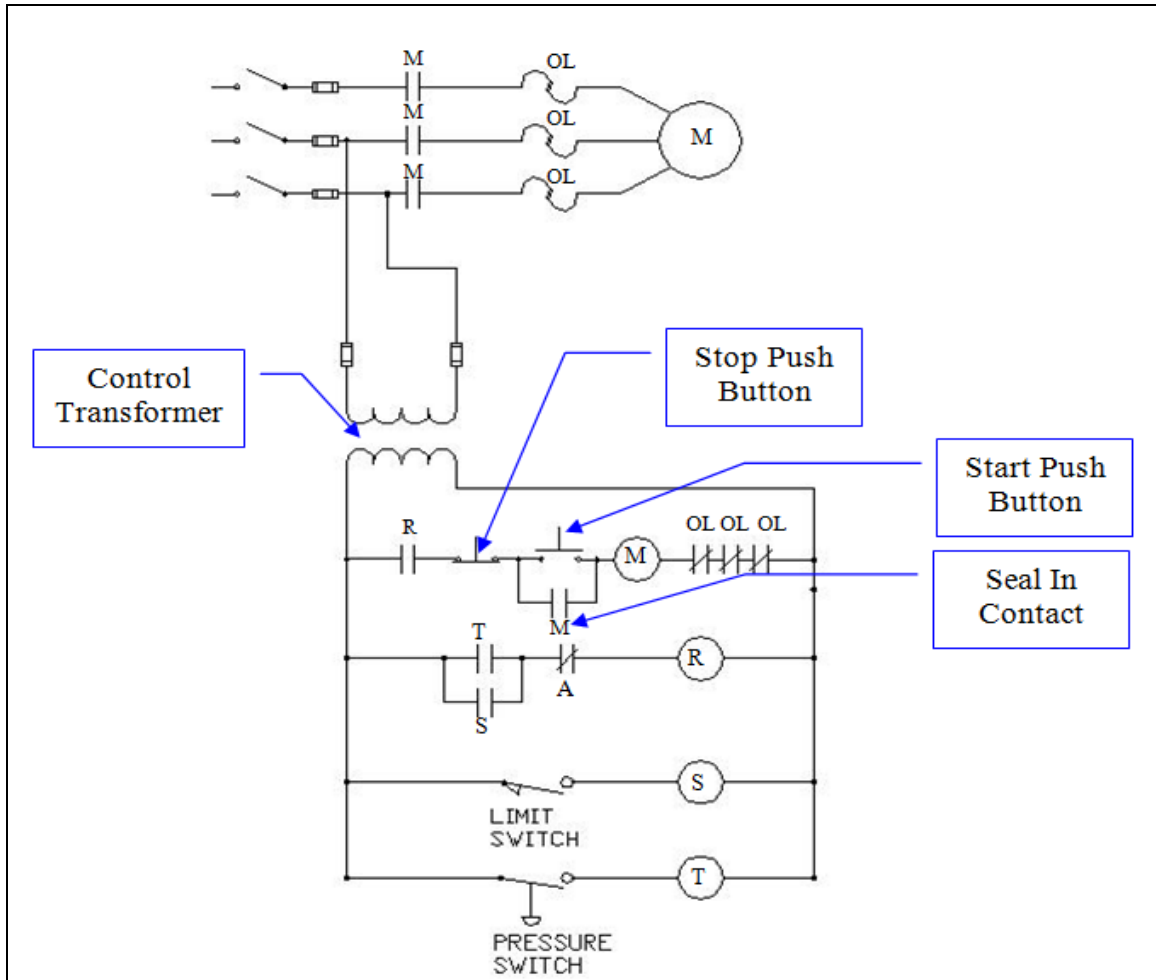

Figure 27 – Basic Automatic Motor Starting and Control Circuit

### Modern Automatic Motor Controls

Modern Automatic Motor controls are normally placed inside a cabinet. This cabinet is a modular unit that contains a series of starters. The starters are mounted inside a sliding drawer called a bucket. Buckets are placed in sections. These sections are assembled in a group that makes the Motor Control Center. One of the sections contains the mains. Another section contains the controller or programming device, most common PLC. The programming is made using, among other software tools, a software based ladder. The bucket also houses lights, push buttons, and manual controls. Each individual starter is connected to a common bus (set of copper or copper clad aluminum bars that are connected to a main protection fused switch or breaker). The bus is located on the back of the cabinet. Wiring is normally placed and routed inside specific protected areas in each section. An MCC section is shown below.



## INTRODUCTION OF CONTROL AND INSTRUMENTATION

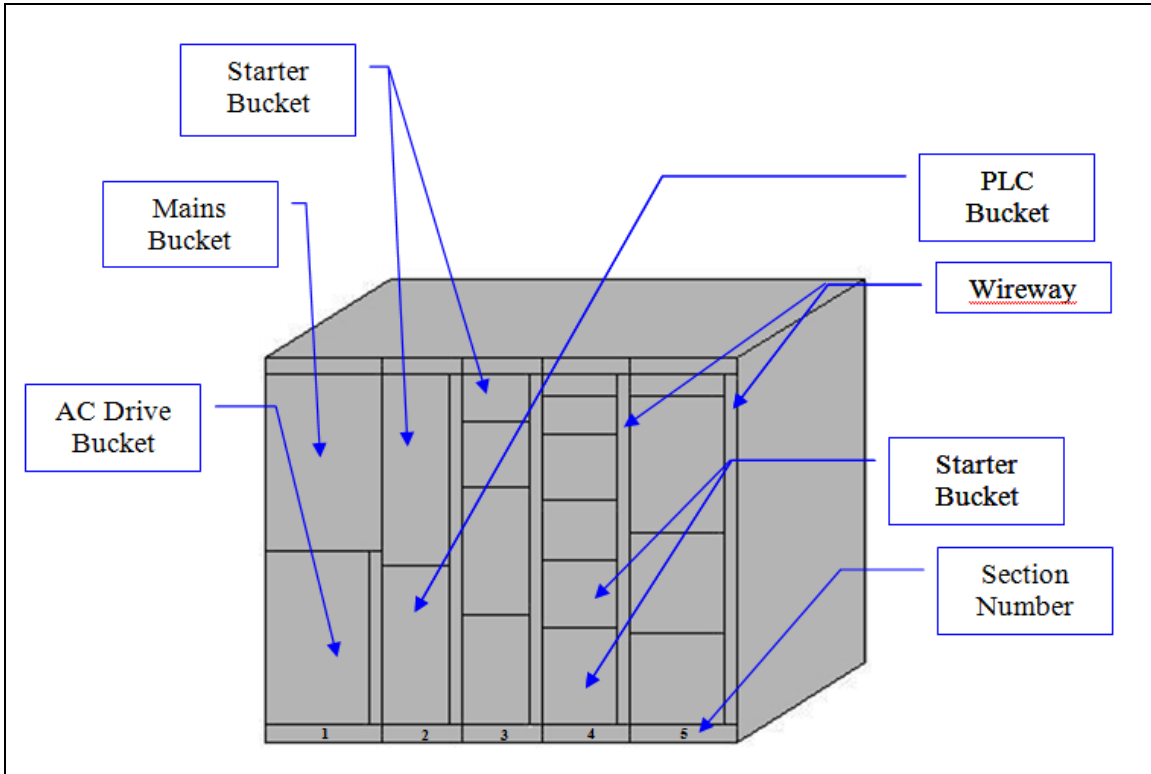

**Figure 28 – Motor Control Center**

Item	Description
Mains Bucket	Includes the main switch or breaker that feeds the entire MCC The protection is designed to protect the bus system.
AC Drive Bucket	This space houses an AC drive which can control the start stop and speed ranges of an AC motor. Other items are a control transformer and accessories to the AC drive.
Starter Bucket	This bucket can contain the starter for a motor. The bucket contains auxiliary relays, control transformer, push buttons, connection boards, and lights that are shown in the starter schematics.
PLC Bucket	The PLC is housed in a space that has enough capacity to house the connection boards and PLC with all the accessories, such as power supply, I/O cards, communication, and control cards, etc.
Wireway	These channels are used to route the control wires from bucket to bucket such as from the PLC to the starters.
Section Numbers	The numbers for each section are attached in this area using a plate. Each manufacturer chooses different layouts according with their design philosophy. The MCC layout shown is a typical Allen Bradley™ design.

**Table 10 –Motor Control Center Components**